

JUNE 4, 2024

Energy Management and Efficient Electrification Series for Ontario
Municipalities

Operating for Energy Efficiency : for water & wastewater treatment Plant Operations

Presented by Stephen Dixon and Andrea Dwight



Overview

Examining how water & wastewater facilities use energy

- Cost, energy & carbon
- Benchmarking
- Performance analysis
- Energy use breakdown

Identifying opportunities

- Waste – Efficiency – Supply Options
- RETScreen Expert Archetypes
- Typical process systems measures
- Typical support system measures

Energy use in water & wastewater facilities

Cost, energy and carbon

How does your plant look?

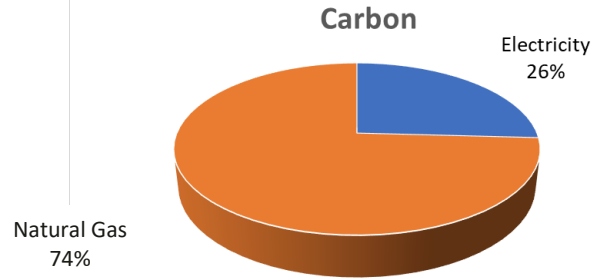
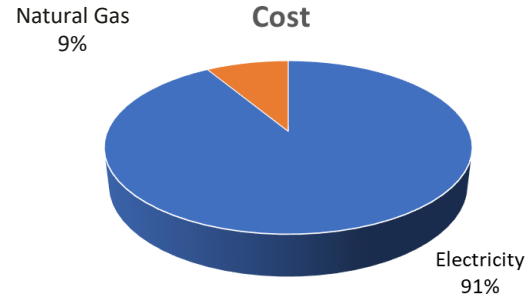
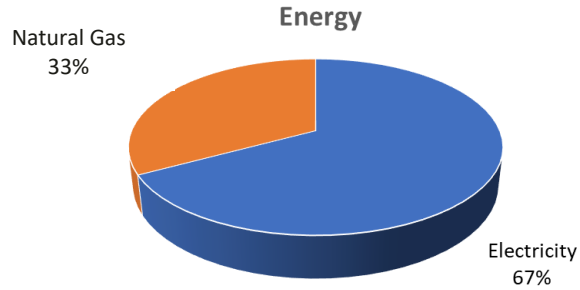

Compare yourself

Externally

- Portfolio Manager
- Sector studies (1)

Internally

- Performance Analysis with RETScreen Expert

Energy Utilization Index (EUI)

- eMWh/ML

Source : [Water Treatment Plants and Pumping \(IESO\)](#)

RETScreen - Facility Subscriber: Tds Dixon Inc - Professional

Facility information

Facility type	Commercial/Institutional
Type	Services
Description	Wastewater treatment plant - Feasibility Emission Target - 80-90%
Prepared for	Prepared for
Prepared by	Prepared by
Facility name	Archetype
Address	Address
City/Municipality	Vaughan
Province/State	ON
Country	Canada

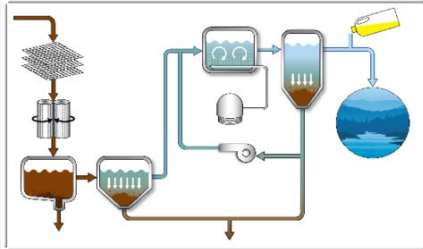

Benchmark - Commercial/Institutional - Services

Facility size - Actual	10,220,000	m ³
Facility size - Archetype	10,220,000	m ³

Fuel type	Fuel consumption		Facility - Plan		Energy use intensity			
	Fuel consumption - base case	Fuel consumption - Equivalent kWh	Fuel consumption - Equivalent kWh	Fuel consumption - Equivalent kWh	Base case	Proposed case	Benchmark	Variance
	kWh	Base case	Set target	Proposed case	kWh/m ³	kWh/m ³	kWh/m ³	Proposed case
Electricity - kWh	4,843,866	4,843,866	-19%	3,936,252	0.47	0.39		
Natural gas - m ³	470,536	5,000,753	-100%	0	0.49	0		
Biogas - m ³	0	0	—	2,748,666.6667	0	0.27		
Total		9,844,620	-32%	6,684,918	0.96	0.65		

Benchmarking from WWTPs in Ontario

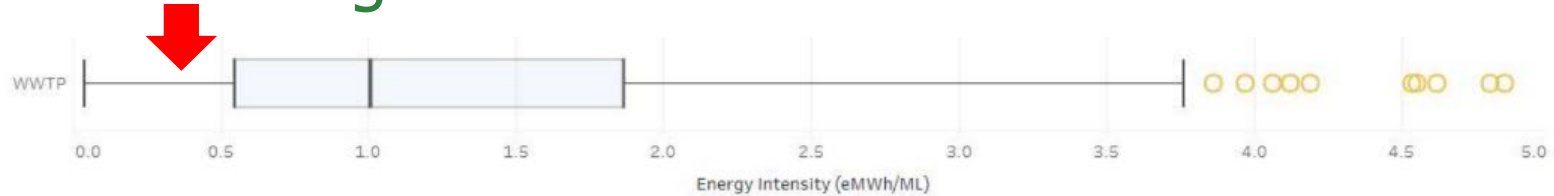

- 75% of Ontario WWTPs have energy intensities that are better (lower) than 1.87 eMWh/mL (right edge of the box);
- 25% of Ontario WWTPs have energy intensities that are better (lower) than 0.55 eMWh/mL (left edge of the box);
- The median energy use intensity for WWTPs is 1.01 eMWh/mL (the line that divides the box);
- Outlier facilities have energy intensities greater than 3.76 eMWh/mL (the right whisker) or lower than 0.04 eMWh/ML (the left whisker).

Source : [Water Treatment Plants and Pumping \(IESO\)](#)

Comparing the plant to itself using RETScreen

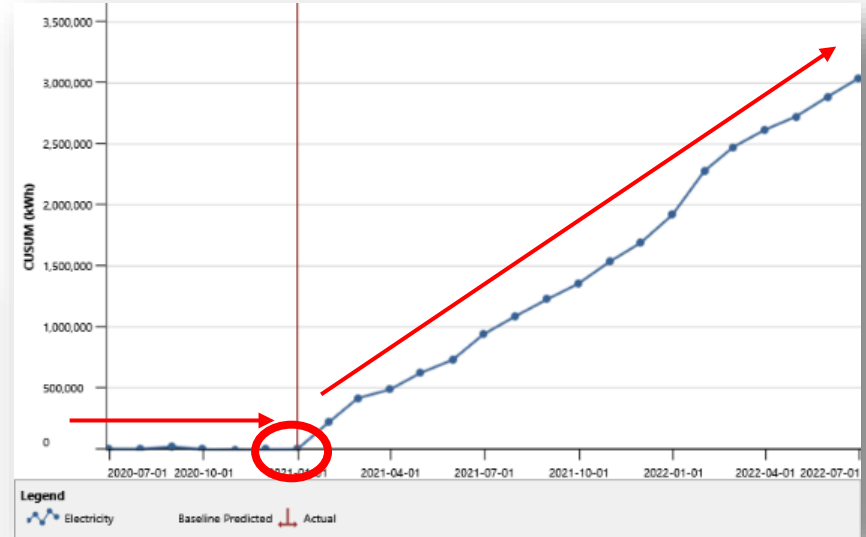
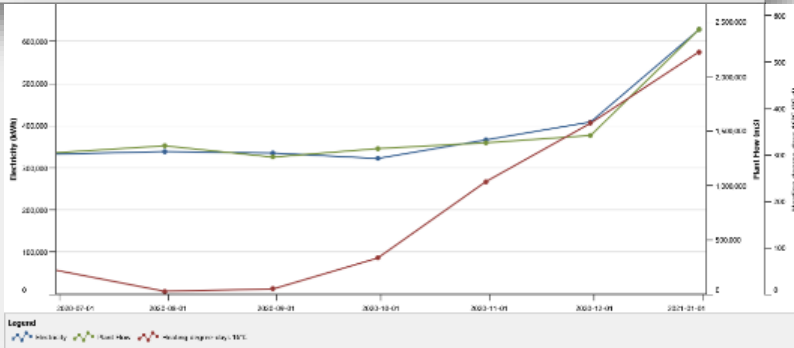
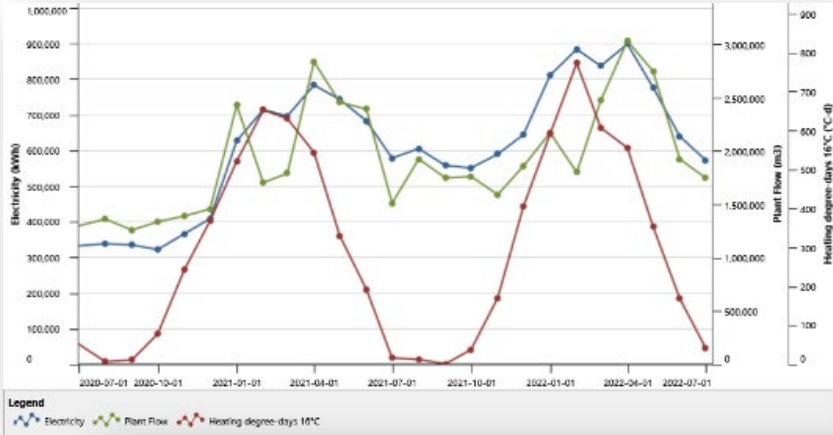

Significant Change in early 2021

Understand when your facility uses energy

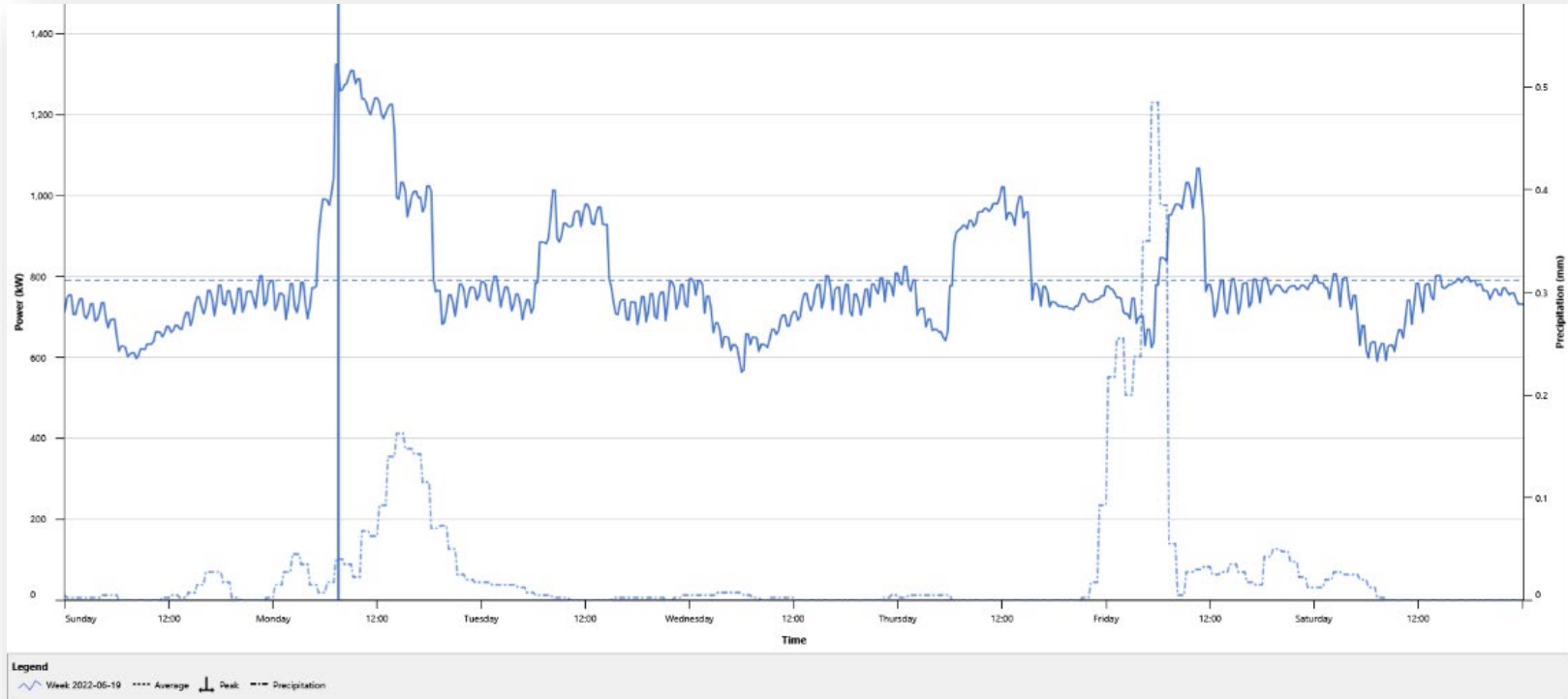

Sample plant – 2023 hourly & peaks

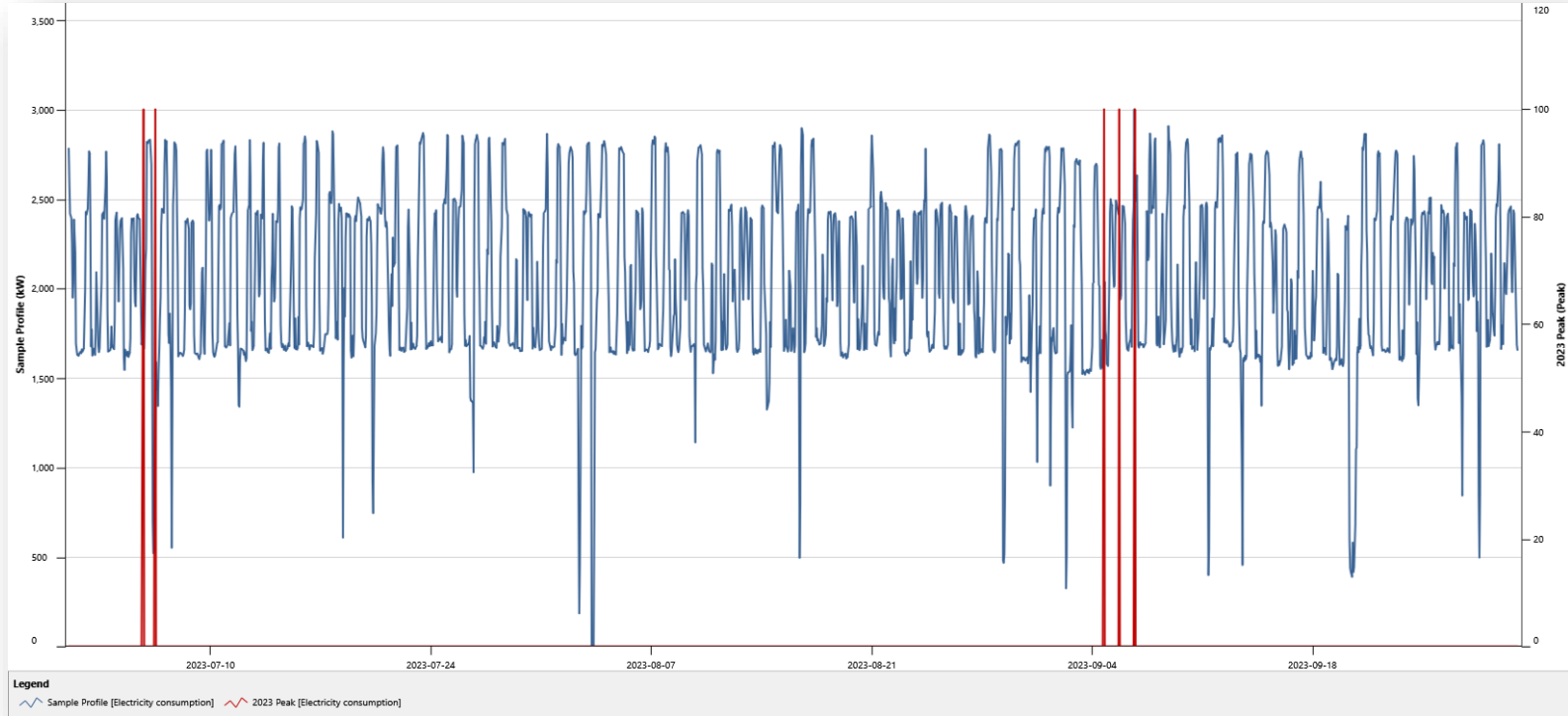

Sample plant – peak week in September 2023

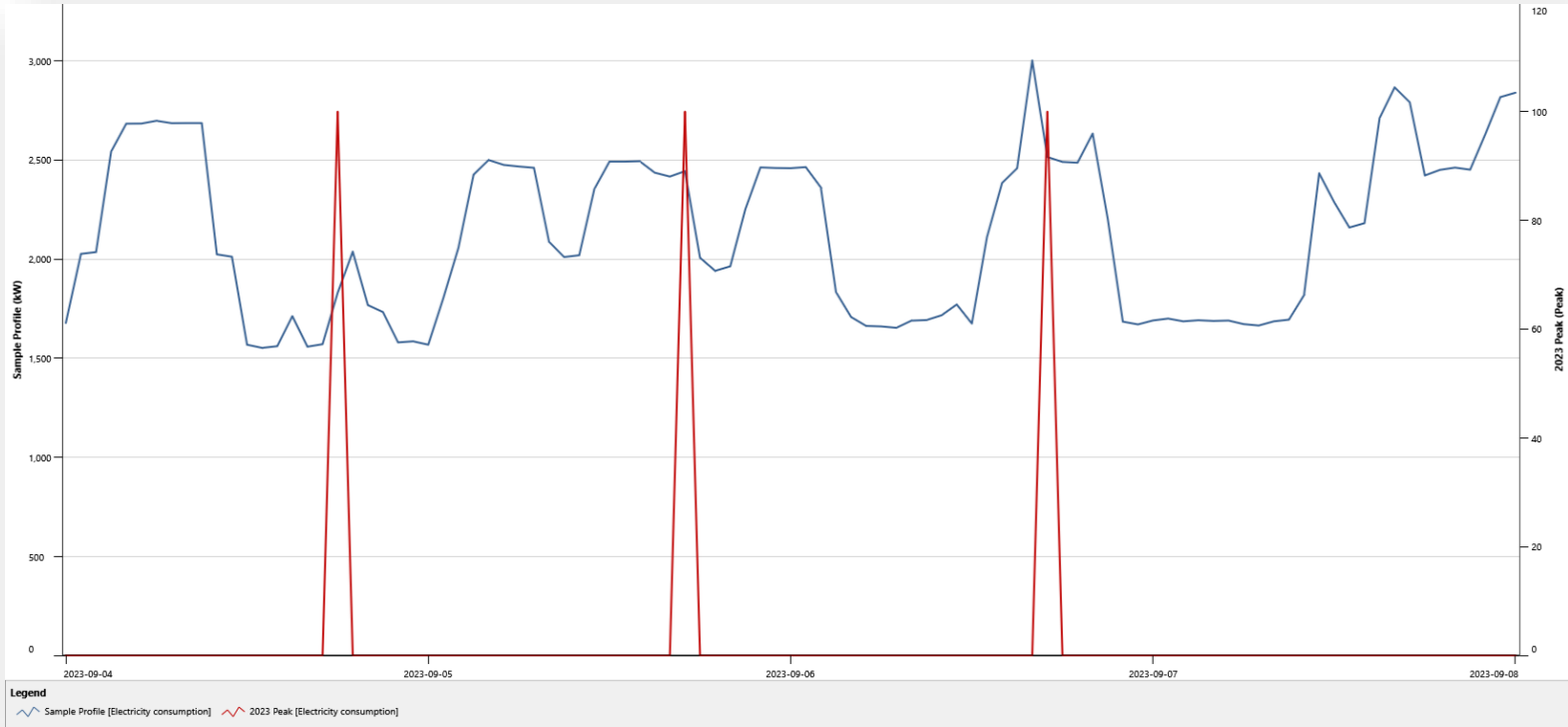

Heat Map – sample plant for 2023

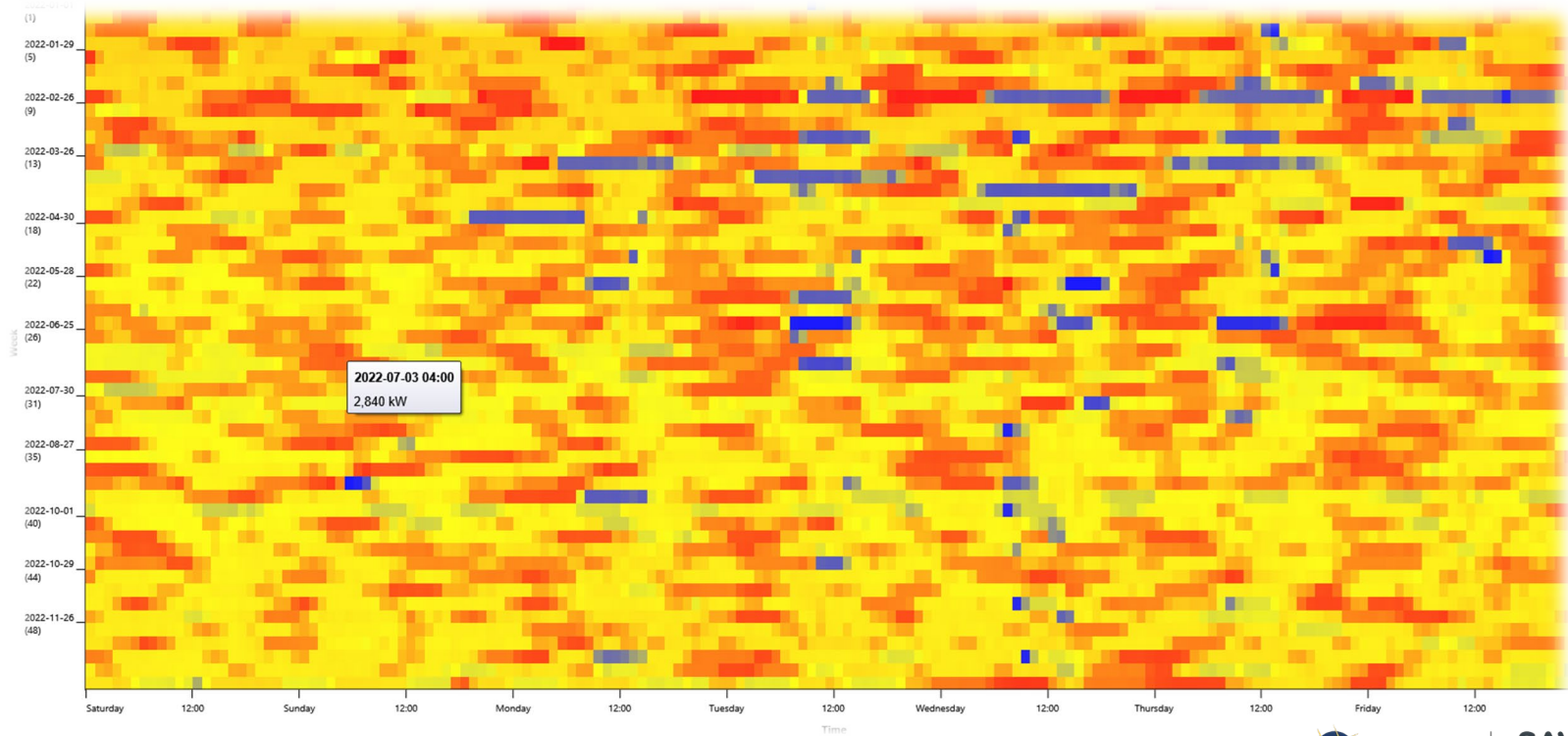

Understand where your plant uses energy

(typical plant breakdown)

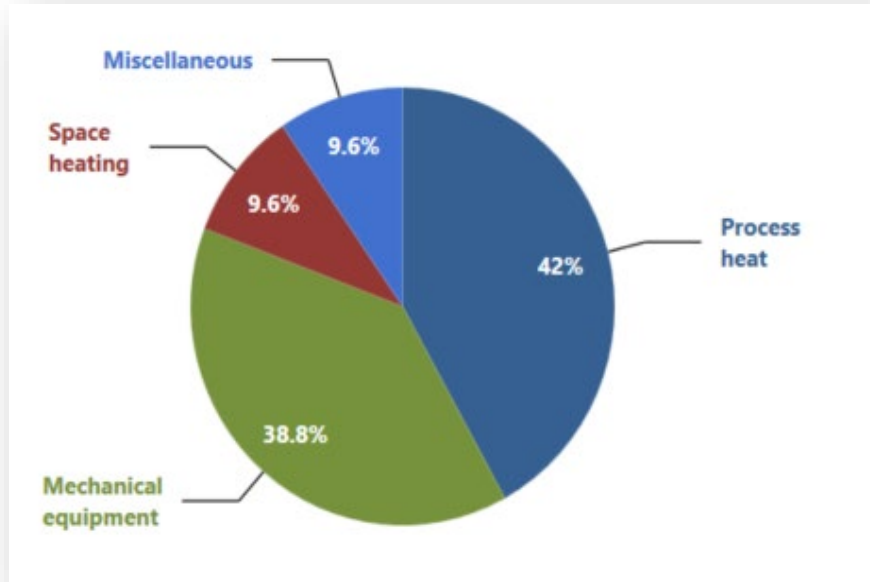

Section	Fuel consumption - base case	
	kWh	%
Process heat	4,133,333	42%
Mechanical equipment	3,820,974	38.8%
Space heating	946,538	9.6%
Miscellaneous	943,774	9.6%
Process electricity	367,920	3.7%
Lights	359,906	3.7%
Space cooling	87,820	0.89%
Electrical equipment	81,451	0.83%
Hot water	46,677	0.47%

Breakdown by system/equipment

(created using RETScreen Expert)

RETScreen Expert

File Location Facility Energy Cost Emission Finance Risk Report Custom

Electricity and fuels Heating Cooling Energy Heating Power Include measure? Comparison Dashboard... End-use... Target... Scaling - Update... Notes... Copy base to proposed Show notes Show image Export to file... Help

Step 1 - Fuels & schedules Step 2 - Equipment Step 3 - End-use Step 4 - Optimize supply Step 5 - Summary Options

RETScreen - Energy Model Subscriber: Tds Dixon Inc - Professional

Commercial/Institutional - Wastewater treatment plant - Feasibility | Emission | Target - 80-90% - Services

Fuels & schedules		Heating	Cooling	Electricity	Incremental initial costs	Fuel cost savings	Incremental O&M savings	Simple payback yr	Include measure?
Electricity and fuels		kWh	kWh	kWh	\$	\$	\$		<input type="checkbox"/>
Fuels consumption - base case									<input type="checkbox"/>
Equipment									
Heating									
Space heating - Office					15,000	727	0	20.6	<input checked="" type="checkbox"/>
Baseboard heater - Office					0	0	0		<input checked="" type="checkbox"/>
Space heating - Process area					180,000	-49,625	0	None	<input checked="" type="checkbox"/>
Space heating - Process area					300,000	0	0	None	<input checked="" type="checkbox"/>
Digester heating					5,000	1,711	0	2.9	<input checked="" type="checkbox"/>
Domestic hot water									
Cooling									
Air conditioning					0	4,391	0	Immediate	<input checked="" type="checkbox"/>
Building envelope									
Office		79,118	69,336		44,004	7,242	0	6.1	<input checked="" type="checkbox"/>
Headworks		275,230			104,214	1,077	0	96.8	<input checked="" type="checkbox"/>
Aeration		79,377			56,136	-391	0	None	<input checked="" type="checkbox"/>
Digester		33,258			43,809	-50.7	0	None	<input checked="" type="checkbox"/>
Ventilation									
Office		43,815	18,483		9,439	985	0	9.6	<input checked="" type="checkbox"/>
Headworks		320,178			4,893	-1,773	0	None	<input checked="" type="checkbox"/>
Aeration		44,485			0	-530	0	None	<input checked="" type="checkbox"/>
Digester		71,076			0	-847	0	None	<input checked="" type="checkbox"/>
Lights									
Exterior pole lights				37,584	12,150	1,555	0	7.8	<input checked="" type="checkbox"/>
Exterior wall packs				21,504	6,080	922	0	6.6	<input checked="" type="checkbox"/>
Process area				124,918	16,740	7,196	0	2.3	<input checked="" type="checkbox"/>
Office/Plant - 1				9,811	4,000	420	0	9.5	<input checked="" type="checkbox"/>
Office/Plant - 2				9,811	3,000	561	0	5.4	<input checked="" type="checkbox"/>
Office/Plant - 3				86,198	9,000	6,255	0	1.4	<input checked="" type="checkbox"/>
Office/Plant - 4				70,080	15,000	5,037	0	3.0	<input checked="" type="checkbox"/>
Electrical equipment									
Office				8,341	0	0	0		<input checked="" type="checkbox"/>

Identifying opportunities

Waste – Efficiency - Supply

Eliminate energy waste

“Match the Need – Right Size”

Turn it off

- Lights, fans, pumps
- Leaky building envelope
- Phantom loads

Turn it down

- Temperature
- Water
- Air flow

Control it

- Aeration (Optimal DO)
- Exhaust / ventilation



Maximize efficiency

Maintenance

- Filters and lubrication
- Clean heat exchangers, pipes, ducts and coils

Combustion Equipment

- Regular tune-ups
- New controls

Optimize compressors, pumps and fans

- Sequence multiple devices
- Operate at most efficient point.
- Variable speed drives

More efficient equipment

- Lighting
 - Lamps &/or re-design
- Compressors & Chillers



Optimize supply:

After reducing waste & increasing efficiency

- **Supply contracts**
 - Green power
- **Supply Alternatives**
 - Biogas
- **Renewable energy**
 - Photovoltaic
 - Solar air, hot water
 - Wind power
- **Heat Recovery**
 - Water & Air
- **Heat pumps**
 - Ground & air source



RETScreen water/wastewater expert archetypes

The screenshot displays the RETScreen Expert software interface. The main window is titled "RETScreen Expert" and features a menu bar with options like File, Location, Facility, Energy, Cost, Emission, Finance, Risk, Data, Analytics, Report, and Custom. The interface is divided into several sections:

- Getting started - Options:** A sidebar on the left contains a "Virtual energy analyzer" option, which is highlighted with a red box.
- Workflow - Per facility:** A central circular diagram illustrates the workflow. It is divided into four quadrants: Performance Tracker (top-left), Virtual Energy Analyzer (top-right), Financial Risk Assessor (bottom-left), and Smart Project Identifier (bottom-right). The workflow is represented by arrows: Start (top), Report (right), Benchmark (bottom-right), Feasibility (bottom), Emission (bottom-left), Finance (left), Risk (top-left), and Data (top).
- Facility type - Examples:** A panel on the right shows configuration options for the Virtual Energy Analyzer, also highlighted with a red box. It includes:
 - Archetypical facilities:** Facility type (Commercial/Institutional), Type (Services), and Description (Wastewater treatment plant).
 - Site reference conditions:** Select facility location (with a search icon) and a search field containing "Search - Facility location".
- Integrated features:** A map view on the far right shows a geographical location, likely Ottawa, with a "Satellite" view option.

At the bottom of the interface, the text "RETScreen Expert - Professional - 9.0.1.94" and "© Minister of Natural Resources Canada 1997-2023." is visible, along with the URL "NRCCan/CanmetENERGY/varenes".

Wastewater plant archetype

Ability	Energy	Target	- 30-40%	- Services				
Show:	All	Heating	Cooling	Electricity				
Fuel saved	kWh	kWh	kWh	kWh				
Incremental initial costs	Fuel cost savings	Incremental O&M savings	Simple payback	Include measure?				
\$	\$	\$	yr					
Heating								
Space heating - Office	0		0	<input checked="" type="checkbox"/>				
Baseboard heater - Office	0		0	<input checked="" type="checkbox"/>				
Space heating - Process area	125,279		500	3,536	-500	0.2	<input checked="" type="checkbox"/>	
Digester heating	0		300,000	0	0	3,000,000...	<input checked="" type="checkbox"/>	
Domestic hot water	0		0	0	0	0	<input checked="" type="checkbox"/>	
Cooling								
Air conditioning		0		0	0	0	<input checked="" type="checkbox"/>	
Building envelope								
Office	49,825	21,669		10,000	7,149	0	1.4	<input checked="" type="checkbox"/>
Headworks	142,543			15,000	4,024	0	3.7	<input checked="" type="checkbox"/>
Aeration	17,824			3,000	503	0	6.0	<input checked="" type="checkbox"/>
Digester	6,483			1,500	183	0	8.2	<input checked="" type="checkbox"/>
Ventilation								
Office	25,473	5,513		4,893	1,270	0	3.9	<input checked="" type="checkbox"/>
Headworks	130,535			4,893	3,685	0	1.3	<input checked="" type="checkbox"/>
Aeration	4,082			0	115	0	Immediate	<input checked="" type="checkbox"/>
Digester	6,382			0	180	0	Immediate	<input checked="" type="checkbox"/>
Lights								
Exterior pole lights			15,552	12,150	1,555	0	7.8	<input checked="" type="checkbox"/>
Exterior wall packs			9,216	6,080	922	0	6.6	<input checked="" type="checkbox"/>
Process area			71,963	16,740	7,196	0	2.3	<input checked="" type="checkbox"/>
Office/Plant - 1			4,205	4,000	420	0	9.5	<input checked="" type="checkbox"/>

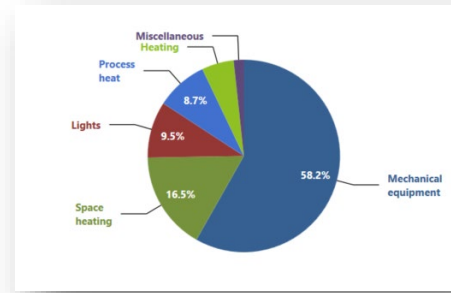

Digester recirculation pump - 2	0	0	0	0	<input checked="" type="checkbox"/>	
Sludge pump	0	0	0	0	<input checked="" type="checkbox"/>	
Grinder pump	0	0	0	0	<input checked="" type="checkbox"/>	
Recirculation pump - Digester	0	0	0	0	<input checked="" type="checkbox"/>	
Flushing water pump	0	0	0	0	<input checked="" type="checkbox"/>	
Fans						
Office	22,590	0	2,259	0	Immediate	<input checked="" type="checkbox"/>
Chapel blower	0	0	0	0		<input checked="" type="checkbox"/>
Aeration blower	333,395	300,000	33,340	0	9.0	<input checked="" type="checkbox"/>
Headworks	0	0	0	0		<input checked="" type="checkbox"/>
Aeration	0	0	0	0		<input checked="" type="checkbox"/>
Digester	0	0	0	0		<input checked="" type="checkbox"/>
Process electricity						
UV disinfection	0	0	0	0		<input checked="" type="checkbox"/>
Process heat						
Digester heating (First 40%)	82,667	10,000	46,670	0	0.2	<input checked="" type="checkbox"/>
Digester heating (Second 30%)	59,615	10,000	1,683	0	5.9	<input checked="" type="checkbox"/>
Digester heating (Third 30%)	59,615	10,000	1,683	0	5.9	<input checked="" type="checkbox"/>
Heating						
Solar water heater	0	0	0	0		<input type="checkbox"/>
Power						
Photovoltaic - 62 kW	0	0	0	0		<input type="checkbox"/>
Total	722,545	27,182	1,491,068	924,756	221,011	-500 4.2

Archetype - Proposed case

This wastewater treatment plant is a conventionally activated sludge plant with secondary treatment. The rated average daily flow is over 28,000 m³/d. This plant includes raw sludge pumping. The liquid treatment train includes coarse screening, grit removal and primary clarification.

Schedules

- Adjust temperature settings and schedules.

Heating system

- Implement annual boiler tune-ups.

Building envelope

- Reduce air leakage at windows, doors and building cracks. Apply caulking around building joints and windows. Replace weather stripping on all doors.

Water plant archetype

Feasibility Energy Target - 30-40% - Services	Heating	Cooling	Electricity	Incremental initial costs	Fuel cost savings	Incremental O&M savings	Simple payback yr	Include measure?
Show: All	kWh	kWh	kWh	\$	\$	\$	yr	
Heating								
Space heating - Office	0			0	0	0		<input checked="" type="checkbox"/>
Space heating - Process area	69,389			500	1,959	-500	0.3	<input checked="" type="checkbox"/>
Domestic hot water	0			0	0	0		<input checked="" type="checkbox"/>
Cooling								
Air conditioning		0		0	0	0		<input checked="" type="checkbox"/>
Building envelope								
Process area	418,500			5,000	11,813	0	0.4	<input checked="" type="checkbox"/>
Office	11,378	2,240		5,000	1,362	0	3.7	<input checked="" type="checkbox"/>
Ventilation								
Office/Washroom	12,541	2,281		0	1,482	0	Immediate	<input checked="" type="checkbox"/>
Process area	136,289			4,893	3,847	0	1.3	<input checked="" type="checkbox"/>
Lights								
Process area			31,536	6,480	3,154	360	1.8	<input checked="" type="checkbox"/>
Exterior			24,528	3,400	2,453	0	1.4	<input checked="" type="checkbox"/>
Office - 1			4,415	3,600	442	360	4.5	<input checked="" type="checkbox"/>
Office - 2			6,176	2,250	618	225	2.7	<input checked="" type="checkbox"/>
Electrical equipment								
Office			0	0	0	0		<input checked="" type="checkbox"/>
Other			0	0	0	0		<input checked="" type="checkbox"/>
Hot water								
Hot water			0	0	0	0		<input checked="" type="checkbox"/>
Pumps								
High lift pump - 1			343,960	140,000	34,396	0	4.1	<input checked="" type="checkbox"/>
High lift pump - 2			219,812	180,000	21,981	0	8.2	<input checked="" type="checkbox"/>
Low lift pump - 1			0	0	0	0		<input checked="" type="checkbox"/>
Low lift pump - 2			0	0	0	0		<input checked="" type="checkbox"/>
Backwash pump			0	0	0	0		<input checked="" type="checkbox"/>

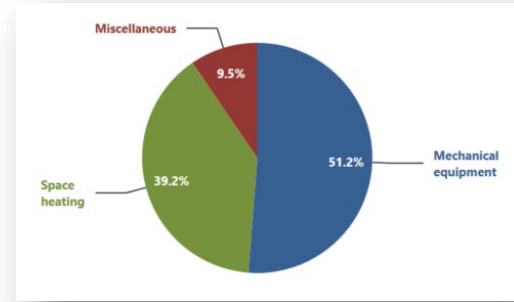

Backwash pump	0	0	0	0	<input checked="" type="checkbox"/>
Recirculation pump - Boiler	0	0	0	0	<input checked="" type="checkbox"/>
Transfer pump	0	0	0	0	<input checked="" type="checkbox"/>
Sampling pump	0	0	0	0	<input checked="" type="checkbox"/>
Fans					
Office/Washroom	15,223	0	1,522	0	Immediate <input checked="" type="checkbox"/>
Flocculation blower	114,935	24,000	11,494	0	2.1 <input checked="" type="checkbox"/>
Exhaust fan - Process	9,964	0	996	0	Immediate <input checked="" type="checkbox"/>
Make-up fan - Process	7,530	0	753	0	Immediate <input checked="" type="checkbox"/>
Process electricity					
Mixing Flocculation Sedimentation Filtering	0	0	0	0	<input checked="" type="checkbox"/>
Chemicals pump	0	0	0	0	<input checked="" type="checkbox"/>
Compressed air					
Compressor - Main	44,040	3,000	4,404	0	0.7 <input checked="" type="checkbox"/>
Heating					
Solar water heater	0	0	0	0	<input type="checkbox"/>
Power					
Photovoltaic - 94 kW	0	0	0	0	<input type="checkbox"/>
Total	648,096	4,521	822,118	378,123	102,675 445 3.7

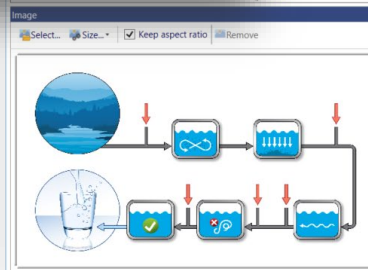

Archetype – Proposed case

This water treatment facility is a conventional water filtration plant with a daily flow capacity of 40,900 m³/d. Influent from an adjacent surface water source (river) is conveyed via low lift pumps to a chemical conditioning mixing chamber. The process includes coagulation, flocculation, and sedimentation followed by dual media filtration for the removal of colour, turbidity and clarification.

Schedules

- Adjust temperature settings and schedules.

Heating system

- Implement annual boiler tune-ups.

Building envelope

- Reduce air leakage at windows, doors and building cracks. Apply caulking around building joints and

Typical process measures

Pumps

- ✓ Pump upgrades
- ✓ Pump sequencing/scheduling/controls
- ✓ Motor upgrade
- ✓ Installation of VFD/VSD
- ✓ Trim pump impeller
- ✓ Installation of Jockey pumps to 'right size' system

Blowers

- ✓ Aeration blower upgrade and controls
- ✓ Grit and channel blower upgrades

Aeration

- ✓ Diffuser upgrade (coarse to fine bubble)
- ✓ Dissolved Oxygen (DO) control
- ✓ VFDs
- ✓ Turbo Blowers

UV Systems

- ✓ Controls - effluent flow, lamp power and water quality
- ✓ Modular design - turn down ratios

Water distribution system optimization

Pumping Optimization

Take a total system approach

- Review with both an operations and energy optimization lens.

Review piping distribution and look for opportunities to optimize control and scheduling of pumps

- Install VFDs on pumps to facilitate tighter controls
- Avoid running pumps in parallel
- Enhance controls to run pumps at the optimal place on their performance curves.

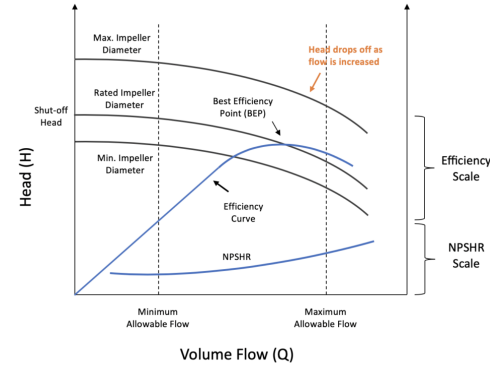

Review whether water can be distributed from different sources depending on seasonal or daily demand.

Water distribution system optimization (continued)

Pumping Optimization

Enhance Energy Tracking of pumping system by:

- Making use of energy measured by VFDs and tracking through control systems and,
- Install meters on large motors
- Use data to optimize control scenarios

Flow control – remove and upgrade any systems that use downstream valves to control flow

Identify and fix water leaks

Can water be processed and pumped to water towers at night?



From the field:

Local Municipal Pumping Optimization Example:

Completed Enhancements by the Operations Team:

- Removed throttle valves downstream of pumps and replaced pump motors and added VFDs
- One pump house had two wells – changed programming to prohibit pumps from running at same time to water tower

Next Steps:

- Review pump curves to determine optimal load range for various pumps
- Programming control system to track energy consumption from installed VFDs and installing amp meters on power to motors without VFDs
- Reviewing total system control to determine optimal pump sequencing from multiple pumphouses to water tower

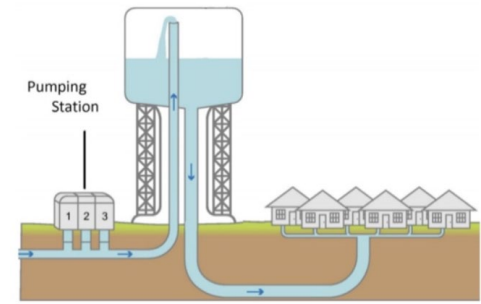

Example: grit chamber aeration

Background:

Two blowers running in parallel with a combined load of ~ 60kW into the grit chambers

Airflow delivered seemed higher than expected given plant flow for the two grit chambers:

- Referred to original specs & designer to determine optimal air flow. (Medcaff and Eddy)
- Reduced blower operation from two to one
- Continuous Load dropped by 50% (to 28 – 32 kW)
- Saved \$37,000/yr of electricity

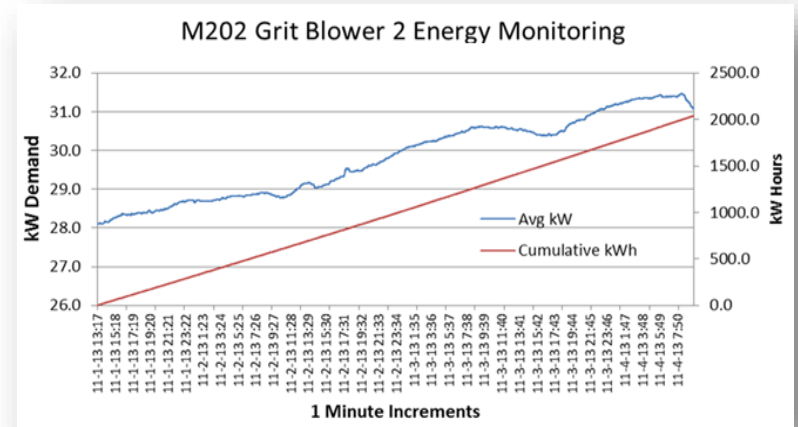

Example: oversized secondary RAS pumps

Background: Existing pumps were oversized

- Sized for 450 L/s but operating at 250L/s
- System efficiency estimated at 47%
- Running at maximum turndown point – this caused operational issues with controlling sludge blanket level

Found a right sized spare pump onsite

- Installed in parallel as a jockey pump (this is often allowed by ECA if the original pumping equipment is not changed)
- **Energy Saved = \$28,000 annually**

Additional Note: Existing pumps were using potable water for seal flushing (26 m³/day (\$\$\$)). This was changed to mechanical seals.



Aeration blower control

System Objectives:

- Satisfy Oxygen demand of treatment process.
- Achieve process requirements at lowest possible cost

Several Areas of Control:

- DO control to optimize airflow
- Blower control to optimize efficiency
- Blower protection to maintain investment
- Minimum airflow to keep solids in suspension



Aeration system opportunities

DO Control

- Pressure vs. Flow Control (most open valve (MOV) control). Up to 10% increase in efficiency.
- Sensor maintenance
- Location of sensors
- Setpoint adjustment



Airflow System

- Optimization and balancing of air to diffusers (basin/zone air control)
- Diffuser cleaning and maintenance
- Control valve maintenance

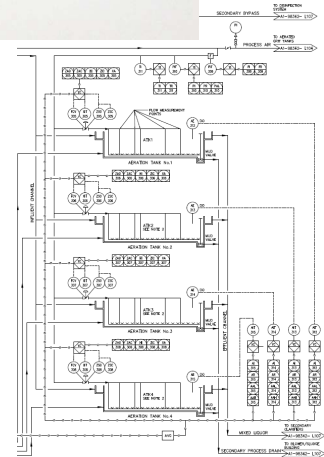

Aeration system opportunities

Blowers

- Install High Efficiency Blowers
- VFD control
- Minimize system discharge pressure and inlet losses
- Ensure filter maintenance

Primary clarifier performance

- Test and maintain primary clarifier performance
- Lowering BOD loading upfront reduces aeration requirements

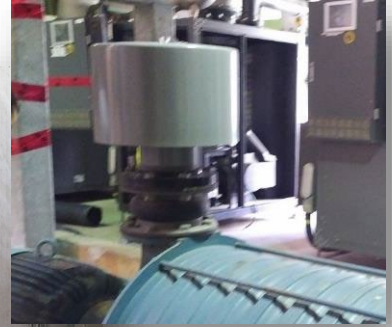
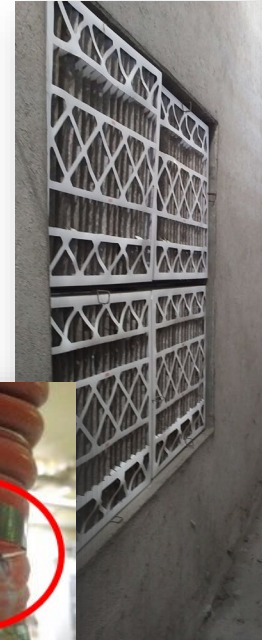

Aeration technologies

Blower Type	Throttling (least efficient)	Variable Speed (VFD) (most efficient)
Mechanical Aerators	N/A	Common
Lobe Type Positive Dis.	Never	Only Practical Method
Screw Type Positive Dis.	Never	Only Practical Method
Multistage Centrifugal	Very Common	Very Common
Geared Single Stage Centrifugal	Uncommon	Uncommon
Gearless Single Stage Centrifugal	Uncommon	Always Provided



Blower design factors

Blower Design Considerations

- Centrifugal Blowers must operate on performance map
 - Flow too low or pressure too high = surge
 - Flow too high or pressure too low = choke
 - Performance varies with air density
- Summer (high loads, low air density)
- Winter (low loads, high density)
- Magnetic vs. Airfoil Bearings

Turbo Blower Advantages

- Higher efficiency than conventional rotary lobe technology
- Small footprint reduces cost to design new and retrofit blower rooms
- Integrated package including blower, motor, and controllers makes installation easier



Turbo Blower Limitations

- Can have a more limited operational range relative to pressure and airflow
- Limited on/off cycling due to airfoil bearing limits, and limited wear on electronic components

Typical support system measures

HVAC Systems

- ✓ Upgrades / Optimization
- ✓ Controls – Programmable Thermostats, Setpoint Reviews
- ✓ Heat and Energy Reclaim
- ✓ Stack Effects in High Bay Spaces

Fans

- ✓ VFDs on exhaust/supply fans
- ✓ Review of ventilation requirements

Other

- ✓ Compressed air measures
- ✓ Reduce/fix piping distribution leaks
- ✓ Implement metering and controls
- ✓ Waste Energy Recovery from incineration process
- ✓ Lighting upgrades and controls (sensors, photocells, etc.)
- ✓ Power factor correction



Field example: HVAC controls

This is often overlooked!

- Heating System and Unit Heater Controls are often inadequate and not a priority to maintain.
- Many buildings are typically unoccupied and can be maintained at a lower setpoint (suggest 15°C).
- Don't underestimate the contribution of electric heating to your overall demand and consumption.

The 140 kW step change in demand is from poorly controlled electric heating.

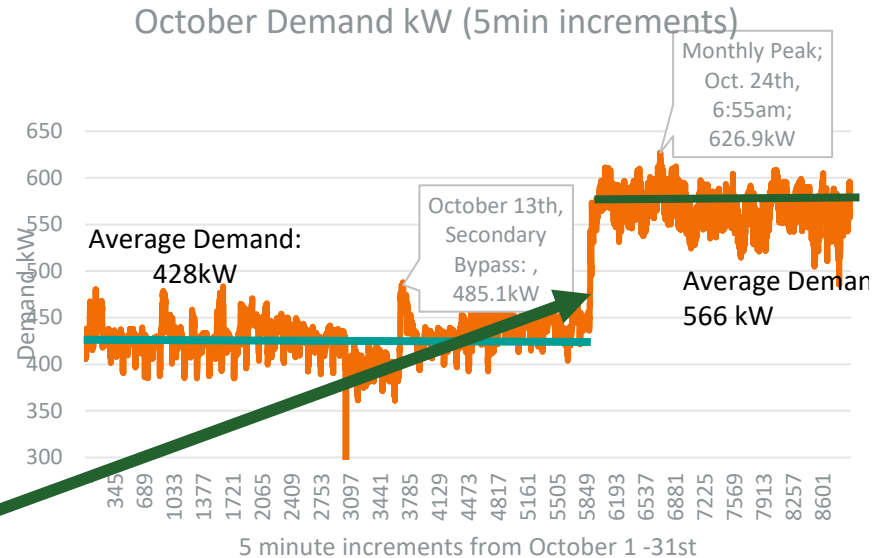

Field example: heating & ventilation

Natural Gas systems can often be overlooked as it is still a relatively low-cost energy source

- Importance of energy monitoring (even from just monthly bills)
- Building systems can be oversized or programming can drift over time.
- Check and optimize thermostat location

Inefficiencies in Natural Gas systems lead to unnecessary Greenhouse Gas emissions.

**Natural Gas Consumption (m³)
Office, New Headworks, Boiler/Digesters**

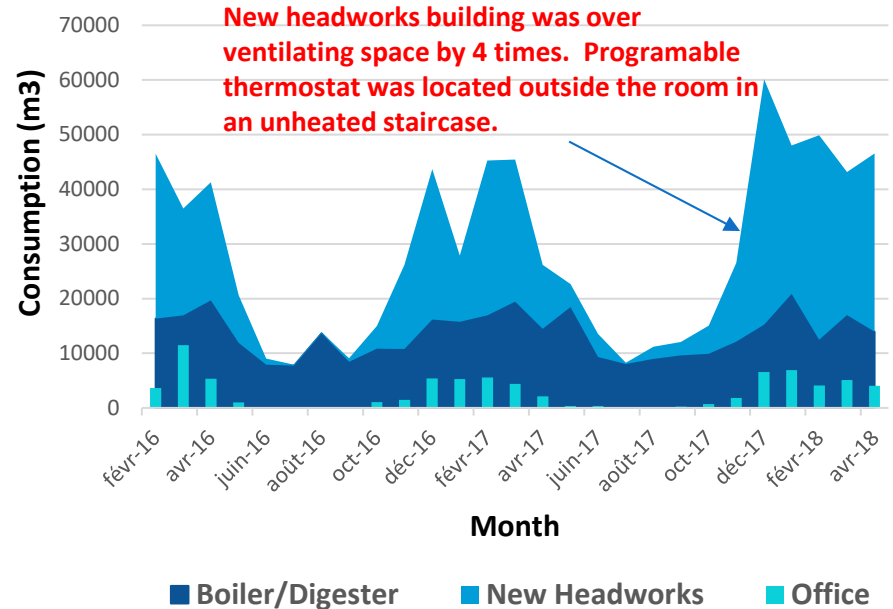

Field example: support systems running when not required

Background:

- Bypass Systems
- Stand-alone building included pumps and odour control system
- System load = 53 kW when shut down, and 68 kW when running
- Run less than 20 days / year

Odour control system controls upgraded to shut down when system not in use.

Saved ~30kW of unnecessary electrical load.

- Consumption and Demand Savings
- Global Adjustment Savings

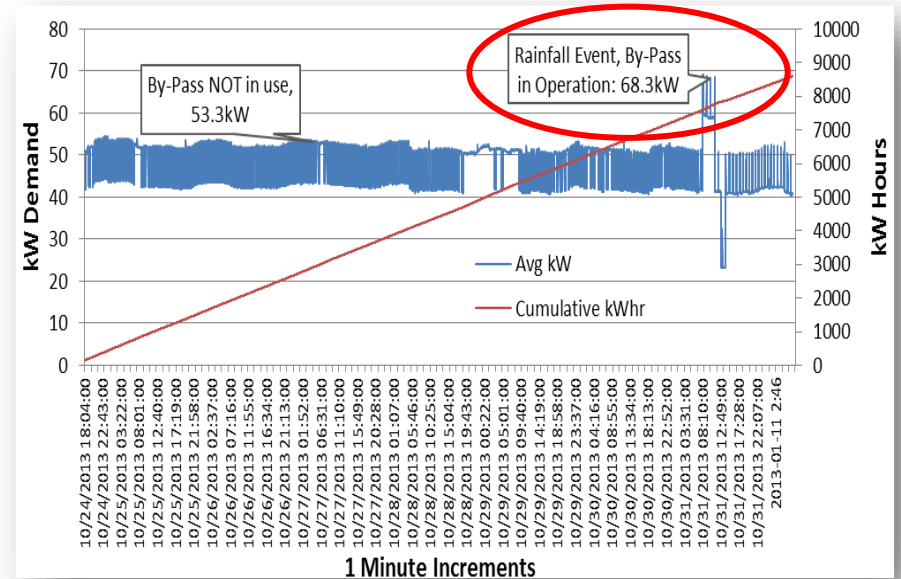

Field example: HVAC system findings



Thermostat on electric heaters lack fine control and scheduling.

Often stop working properly after only a couple of years. Should have wall mounted programable thermostats.



**HVAC
Maintenance
Issues**



Don't forget the building envelope:



Fix gaps around doors.



**Hard to reach windows in outbuildings are opened in the summer and then left open in the winter.
Stack effect can increase heat losses.**



Older windows can sometimes be damaged and have minimal thermal integrity

Field example: water consumption reduction

Background:

- Plant effluent being used in various part of the plant including the process, foam control, tank cleaning and flushing.
- Water was running continuously through an incline compactor conveyor in the headworks (6L/min) that only ran intermittently.
- Traced line and found it was potable water not effluent.

Results:

- Interlocked water with conveyor drive motor to run water only needed
- Saved 1,800 m³ water annually and \$5,700 of potable water ch
- Changed water source to plant effluent reducing water charges



Field example: effluent pumping system

Background:

- Monitored plant effluent pump load for a week.
- Pump cycling more frequently than expected.

Action Taken:

- Reviewed all visible piping.
- Found and fixed two leaks in piping loop
- Reduced pumping energy consumption by 25% but more importantly reduced wear and tear on pump due to reduced cycling



Renewable energy sources: solar walls and turbines

Solar Walls:

- Installed over cladding
- No moving parts
- Heated air rises through channels to top and is collected and fed into HVAC inlet
- Reduces inlet air heating requirements



Micro Hydro Turbines:

- Take advantage elevation differences in outfall from plant to discharge source
- Example: Clarkson WWTP

Renewable energy: heat recovery from effluent

Huge water volume therefore large heat recovery opportunity available:

- Temperature of effluent does not change much from winter to summer (typically 10-13°C in winter compared to outdoor air that could be -20°C)
- Picture is an example of a tank version that would be installed in a depression in the effluent channel

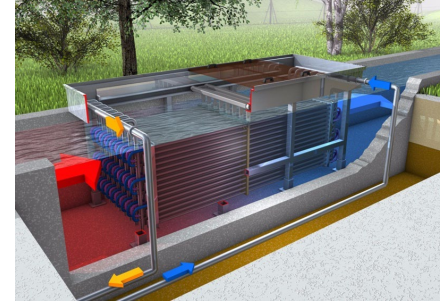

Source : [Huber Technology : Wastewater solutions](#)

Systems have been installed on sanitary sewer trunk lines and at WWTPs.

- Toronto Western Hospital Wastewater Energy Transfer System (WET) Project
- Use of Heat Pumps to preheat process water (Membrane Flushwater)



Multiple resources available

- **Find multiple type of resources on Save on Energy website :**
<https://saveonenergy.ca/Training-and-Support>

Webinars

Fact sheets

M&V templates

Practical guides

- **Sign up for a one-on-one coaching:** [Post-webinar support intake form](#)
 - Coaching sessions conducted virtually: phone, video calls, and email
 - Designed for organizations seeking guidance.

Thanks for the Opportunity to be of Service!

“The help desk is now open!”

Stephen Dixon

sdixon@knowenergy.com

Andrea Dwight P.Eng., CEM, CMVP

andrea@bskyeng.com

Christian Tham

cthamb@amo.on.ca



Thank you!

[SaveOnEnergy.ca](https://www.saveonenergy.ca)

trainingandsupport@ieso.ca



@SaveOnEnergyOnt



facebook.com/SaveOnEnergyOntario



linkedin.com/showcase/
SaveOnEnergy-Ontario



Stay in the know

Sign up for Save on Energy's
quarterly business newsletter